

Description

The CANA-232/CANA-485 are a family of adapter boards/modules that allow a host PC, PLC or microcontroller to communicate with a network of up to 64 US Digital T7 inclinometers. The CAN adapter is only needed to communicate with the USD-CAN interface version of the T7. The RS232 version of the T7 can connect to a RS232 port without an adapter.

The CAN adapter serves as a command translator between a host serial port and the USD-CAN bus used by the T7 network. RS-232 or RS-485 can be used on the host side, depending on the type of adapter used. The adapter frees the user from a complicated network interface on the host side. A host can access every T7 on the network by sending/receiving simple serial port commands to/from the CAN adapter. The underlying serial commands used by both adapter boards are identical. For example, to read the angle from a particular T7, the host simply sends a serial command to the CANA-232/CANA-485 adapter which contains the command type and the address of the destination T7. The CAN adapter board translates the serial port commands from the host to the USD-CAN protocol and handles all network functions (access, error correction, etc) to access an T7 on the network. Conversely, the CAN adapter also translates the reply data from the T7 and sends the data back to the host on the serial bus. As a result, the CAN adapter makes it very easy for a user to read/write data to network of T7s.

The host side serial interface used by the CAN Adapter is fully documented so that users can write their own serial port command software. A set of simple functions are provided in the included Windows DLL that allow users to read and write data to a network of T7s. A Windows demo application is also included that can display the angles and temperature, as well as setting operating modes, orientation, zero position, damping / averaging time, direction, and more for every T7 on the network.

Software

- ▶ www.usdigital.com/support/software/t7-software
- ▶ www.usdigital.com/assets/USDProducts.zip (.zip file with installer)

Mechanical Drawing

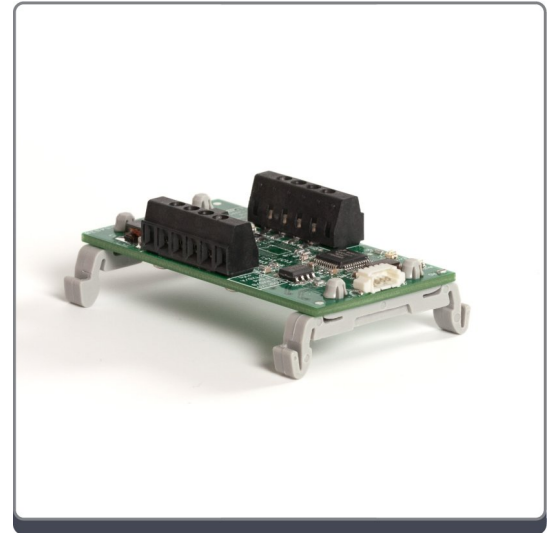

Features

- ▶ Low-cost and compact size
- ▶ Standard 35mm DIN rail mountable
- ▶ Uses CAN (Controller Area Network) bus to provide robust network connectivity
- ▶ One CANA-232/CANA-485 can network up to sixty-four T7 inclinometers
- ▶ Host accesses any T7 on network using simple commands over RS-232/RS-485
- ▶ 700 feet (213 m) max. total cable length
- ▶ Flexible network wiring - daisy chain with or without stubs.
- ▶ Adapter can be located anywhere along network
- ▶ Wide 7.5V to 30V supply range

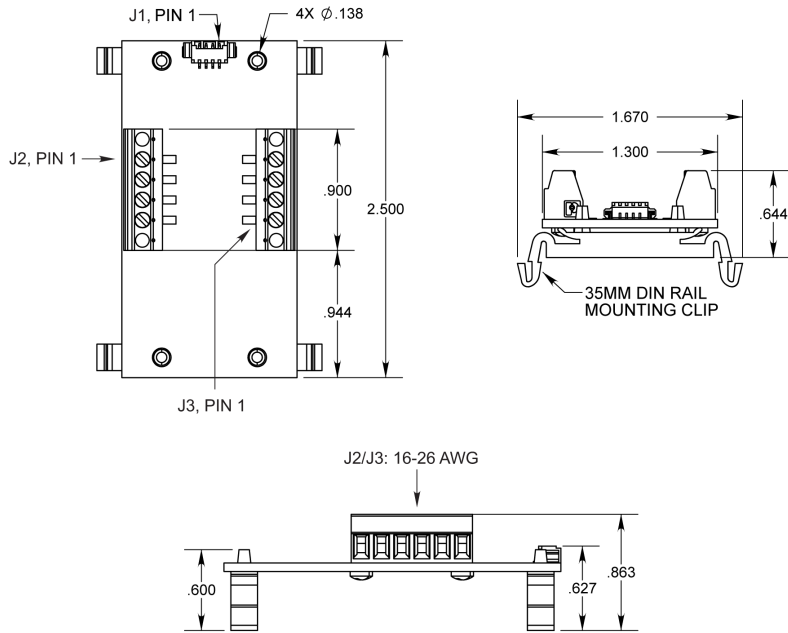

Electrical

Parameter	Min.	Typ.	Max.	Units
Supply Voltage	7.5		30	V
Supply Current (CAN adapter only, excludes current drawn by each T7 over CAN cable)	20mA @ 30V		48mA @ 7.5V	mA
Operating Temperature	-40	25	85	C

USD-CAN Network Size

Parameter	Max.	Units
Number of T7s in network	64	
Cable length to furthest T7 in network (excluding stubs)	700	feet
Individual stub length	16	feet
Total length of all stubs	250	feet

USD-CAN Network Config.

A T7 CAN network consists of a host computer (PC, PLC or microcontroller), a single CANA-232/CANA-485 adapter, cables and T7 inclinometers. Power to each T7 is supplied over the network cable. T7s are connected together as a daisy chain with or without stubs. The CAN adapter can be placed anywhere along the length of the daisy chain. The last T7 device on the daisy chain needs a terminating cable which has a built in termination resistor (see Related Products & Accessories at the bottom of this page). The CAN adapter has a built in termination resistor that can be jumpered in or out using JP1. Typically, the CAN adapter is at one end of the network, so the jumper should be added to include the termination resistor. If the CAN adapter is placed in the middle of the daisy chain, the jumper should be removed (no termination resistor). In this case a terminating cable must be used for the T7s at both ends of the daisy chain. See the sample diagrams below:

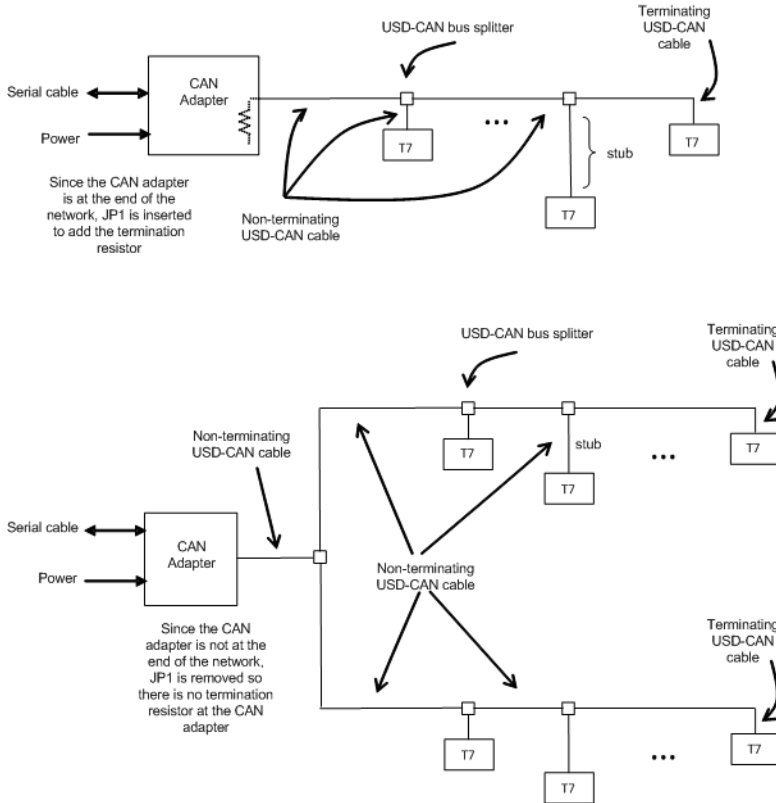

T7 Addressing

Each T7 on the network must be assigned a unique address from 1 to 100 or 127 (decimal). All T7s are shipped with a default address of 127. Address 126 is a special broadcast address - all T7s will listen and respond to commands sent to this address. To assign an address to a T7 unit, connect one T7 to a PC's serial port - either directly if using the RS232 version or through the CAN adapter for the CAN version. The address can be set using the included PC based "T7 Demo" software. Alternately, a host computer can send the "Set Address" serial port command to the CAN adapter. This procedure only needs to be done once for each T7 since the address is stored in non-volatile flash memory.

CAN Adapter Supply Voltage

For a given network configuration, a minimum CAN adapter power supply voltage is needed to ensure that the last T7 on the network is powered by at least 5.5V. The minimum power supply voltage can be calculated based on the number of networked T7s, the cable

resistance/configuration and the current consumption of each T7 as a function of voltage. The following tables show the recommended minimum CAN adapter power supply voltage as a function of cable length and number of T7s for several common network wiring schemes. The tables assume that US Digital CAN cables with a resistance of 3.3 ohms per hundred feet for the two power lines are used. The following data is for room temperature (22C) operation. The nominal supply current is an approximate value that does not include current drawn by the CAN Adapter. Please contact customer service for other possible network configurations.

Recommended minimum CAN adapter power supply voltage for T7s equally spaced on a total cable length, L. Stub length from T-adapter to a T7 is 6 feet.

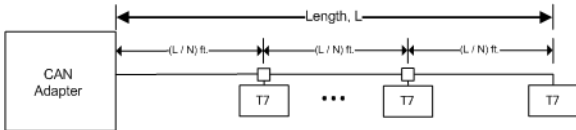

Number of T7's	Nominal supply current	Total cable length, L (T7's equally spaced)							
		100 ft	200 ft	300 ft	400 ft	500 ft	600 ft	700 ft	
1	55 mA	9	9	9	9	9	9	9	
2	110 mA	9	9	9	9	9	9	9	
3	150 mA	9	9	9	9	9	9	9	
4	200 mA	9	9	9	9	9	9	12	
5	250 mA	9	9	9	9	9	12	12	
10	480 mA	9	9	9	12	12	12	12	
15	700 mA	9	9	12	12	15	15	15	
20	910 mA	9	12	12	15	15	15	18	
30	1.4 A	9	12	15	15	18	24	24	
40	1.8 A	12	15	15	18	24	24	24	

Recommended minimum CAN adapter power supply voltage for T7s spaced 9 feet apart after an initial leader cable length, L. Stub length from T-adapter to a T7 is 6 feet.

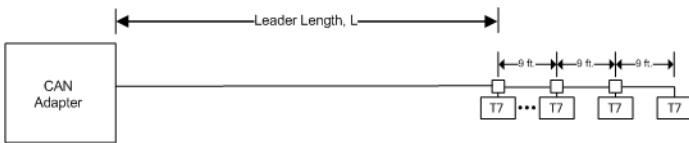

Number of T7's	Nominal supply current	Leader length, L (T7's spaced 9 ft. apart after leader)							
		100 ft	200 ft	300 ft	400 ft	500 ft	600 ft	700 ft	
1	55 mA	9	9	9	9	9	9	9	

2	110 mA	9	9	9	9	9	9	-
3	150 mA	9	9	9	9	9	12	-
4	200 mA	9	9	9	12	12	12	-
5	250 mA	9	9	12	12	12	12	-
10	480 mA	9	12	12	15	15	18	-
15	690 mA	12	15	15	18	24	-	-
20	870 mA	12	15	18	24	24	-	-
30	1.2 A	18	24	24	28	-	-	-
40	1.5 A	24	28	30	-	-	-	-

Pin-out / Wiring

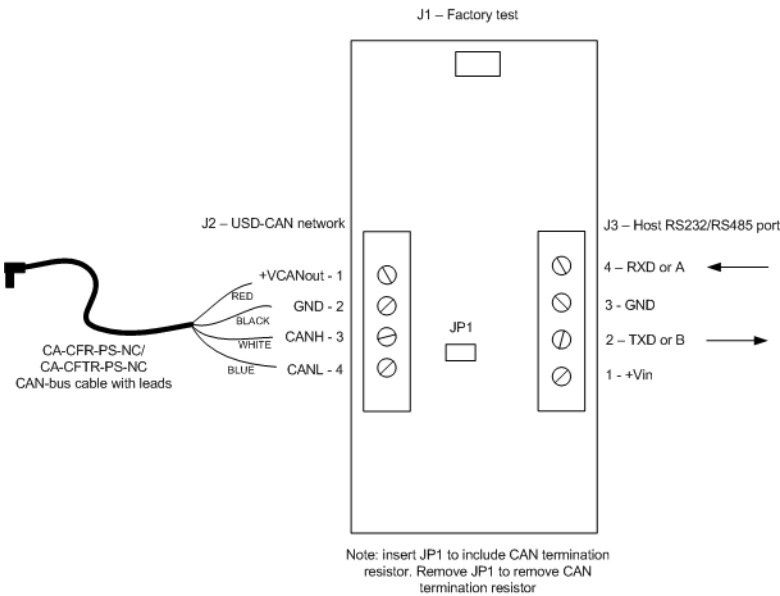

CANA-232 to Typical USB to RS232 Converter wiring

CANA-232, J3	Typical USB to RS232 Converter, serial connector
Pin 1 - +Vin	
Pin 2 - TXD	to Pin 3 - RX
Pin 3 - GND	to Pin 1 - GND
Pin 4 - RXD	to Pin 5 - TX

CANA-232 to PC DB9 serial port connector wiring

CANA-232, J3			PC DB9 serial port connector
Pin 1 - +Vin			
Pin 2 - TXD	to		Pin 2 - RXD
Pin 3 - GND	to		Pin 5 - GND
Pin 4 - RXD	to		Pin 3 - TXD

 Ordering Information

CANA -

Host Interface

232 =RS-232

485 =RS-485

Notes

- Cables and connectors are not included and must be ordered separately.
- US Digital® warrants its products against defects in materials and workmanship for two years. See complete warranty for details.