

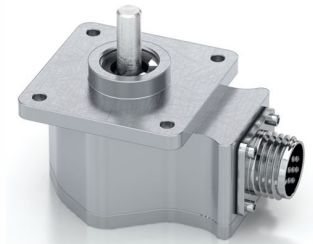

HD25 Features

- NEMA size 25 package
- Anodized aluminum housing
- 64 to 10,000 cycles per revolution (CPR)
- 256 to 40,000 pulses per revolution (PPR)
- 2-channel quadrature output with optional index
- Single-ended or differential outputs
- Sealed IP65 option



HD25 Product Description

The HD25 is a rugged optical incremental shaft encoder designed for heavy-duty industrial applications. The housing, machined from a solid billet aluminum block and finished with clear anodizing, conforms to the industrial standard size 25 package. Size 25 encoders are widely used and considered the backbone of feedback devices found in factory automation and industrial applications. The HD25 will drop directly into existing applications to provide a superior solution at a competitive cost.

Mechanical Drawings

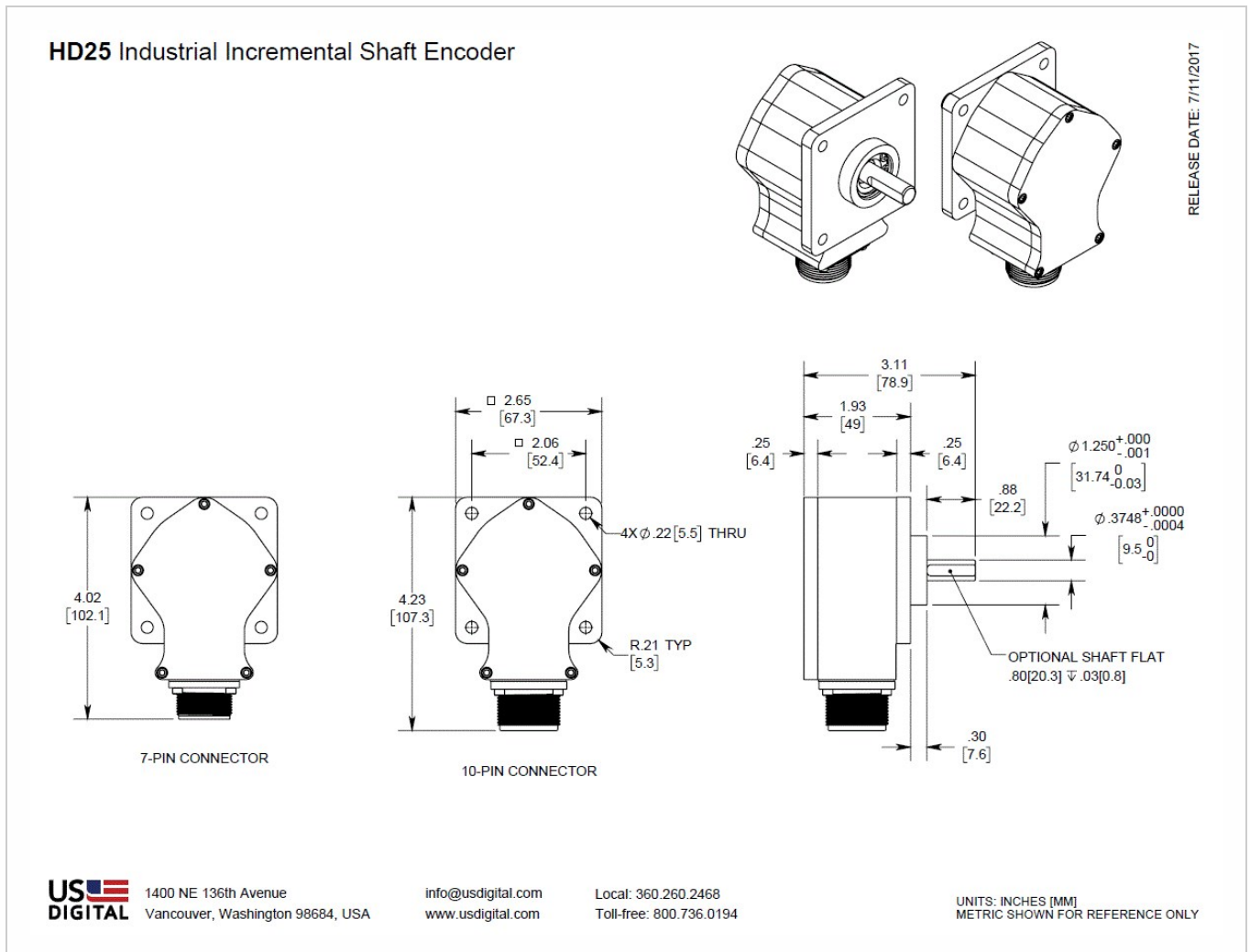



Specifications

ENVIRONMENTAL

Parameter	Value
Operating Temperature	
Low voltage version, CPR < 3600	-40C to 100C
High voltage version, CPR < 3600	-40C to 85C
Low voltage version, CPR ≥ 3600	-25C to 100C
High voltage version, CPR ≥ 3600	-25C to 85C
Humidity	
Non-sealed	98% non-condensing
Sealed	100% condensing (NEMA IP65)
Vibration (5 to 2kHz)	20G
Shock, 11 mSec	60G
Electrostatic Discharge	
Single-ended (-S version), IEC 61000-4-2	± 4 kV
Differential (-D version), Human Body Model	± 2 kV



MECHANICAL

Parameter	Value
Size	NEMA size 25
Housing and Cover Material	Anodized aluminum
Shaft Material	Stainless steel
Weight	17 oz.
Shaft Diameter	0.3748 in. (+0.0000 in. -0.0003 in.)
Shaft Optional Flat Size	.08 in. long x .03 in. deep
Max. Acceleration	100000 rad / sec ²
Max. Shaft Speed (1) Non-sealed (mechanical) Sealed (mechanical)	15000 rpm 6000 rpm
Shaft Torque Non-sealed Sealed	< 0.5 in-oz 3.5 in-oz typical
Max. Shaft Load Axial Radial	40 lb. 35 lb.
Max. Shaft Runout	0.0003 in. T.I.R.
Bearing Life @ 4 Pound Load	2.3 x 10 ⁹ revolutions
Moment of Inertia	2.8 x 10 ⁻⁴ oz-in-sec ²
Technical Bulletin TB1001 - Shaft and Bore Tolerances	Download (https://www.usdigital.com/support/resources/reference/technical-docs/technical-bulletins/shaft-and-bore-tolerances-tb1001/)

(1) The maximum speed due to electrical considerations is dependent on the CPR. See the EM1 (<https://www.usdigital.com/products/encoders/incremental/modules/em1/>) and EM2 (<https://www.usdigital.com/products/encoders/incremental/modules/em2/>) product pages.

PHASE RELATIONSHIP

B leads A for clockwise shaft rotation, and A leads B for counterclockwise rotation viewed from the shaft side of the encoder.



ELECTRICAL

- Specifications apply over the entire operating temperature range.
- Typical values are specified at 25°C.
- Output driver IC: ET7272B
- For complete details, see the EM1 (<https://www.usdigital.com/products/encoders/incremental/modules/em1/>) and EM2 (<https://www.usdigital.com/products/encoders/incremental/modules/em2/>) product pages.

PARAMETER	MIN.	TYP.	MAX.	UNITS	CONDITIONS
Supply Voltage (Vs)					
Low Voltage Version	4.5	5.0	5.5	V	
High Voltage Version	9.5		30		
Supply Current			138	mA	
Low-level Output		0.4	0.5	V	I _{OL} = 20mA
High-level Output		V _s - 2.0		V	I _{OH} = -20mA
Output Rise/Fall Time		700	980	nS	

7-PIN CONNECTOR PIN-OUT

PIN	DESCRIPTION
A	A channel
B	B channel
C	Index
D	+VDC
E	Case ground
F	Common
G	NC

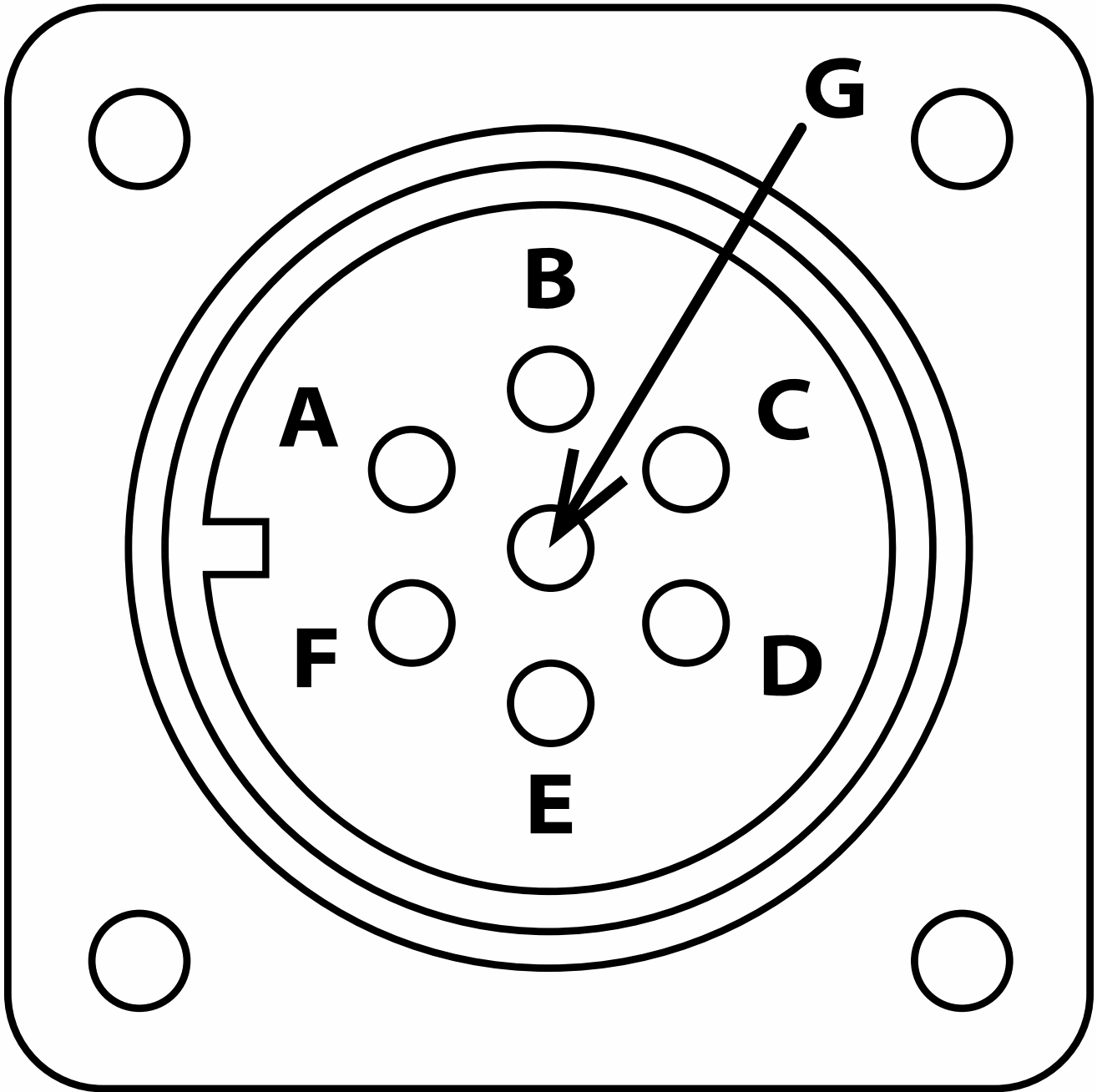

10-PIN CONNECTOR PIN-OUT



HD25 INDUSTRIAL RUGGED METAL OPTICAL ENCODER

PIN	DESCRIPTION
A	A+ channel
B	B+ channel
C	Index+
D	+VDC
E	NC
F	Common
G	Case ground
H	A- channel
I	B- channel
J	Index-

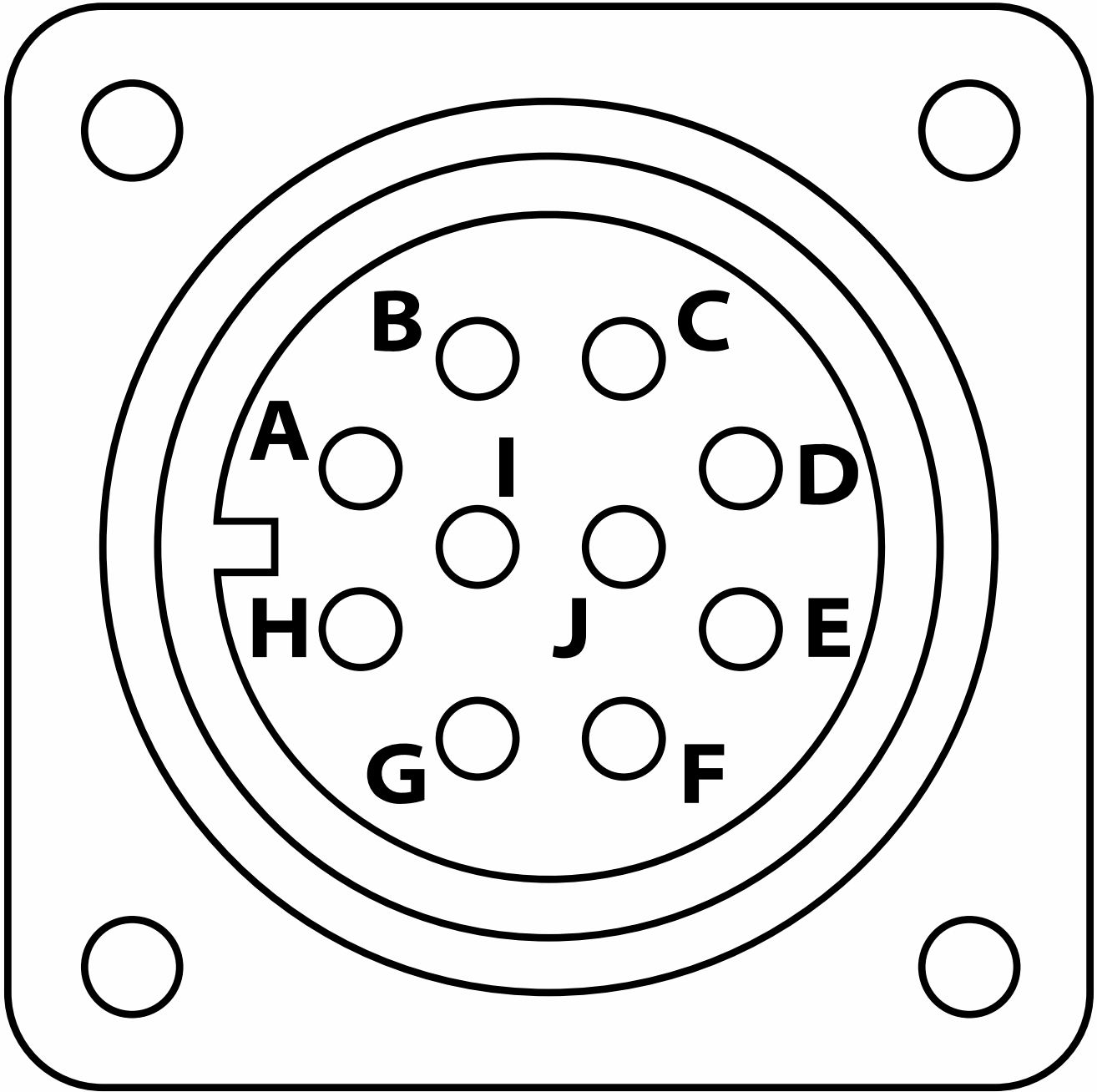



PRODUCT CHANGE NOTIFICATIONS

Title	Date	Description	Download
EM1 & EM2 Update - PCN 4199	1/14/2014	Based on our continuous process improvement program, US Digital is changing the current marking method for our EM1 and EM2 encoder modules to a serialization method. This change will allow for each module to have a unique code; the current marking method is based on a date code system that includes all encoder modules produced within a specific week / year. The serialization system will be based on a hexadecimal system.	Download (https://www.usdigital.com/support/resources/product-change-notifications/pcn-4199-em1-em2-update/)
EM1 LED Die - PCN 1016	2/7/2013	<p>As part of US Digital's continual assurance of supply strategy, we have qualified additional sources for our LED die used in our EM1 encoder module, which in turn impacts all of the following products:</p> <p>EM1, E2, E3, E5, E6, H1, H15, H3, H5, H6, HB5M, HB6M, HD25, PE, S1, S2, S5, S6, T5 and T6</p> <p>The device specification will remain the same, i.e. there will be no change to form, fit or function of the product(s) as specified by US Digital. The appropriate quality and reliability testing has been performed on representative products to ensure normal parametric distribution, consistent with US Digital's quality and reliability standards.</p>	Download (https://www.usdigital.com/support/resources/product-change-notifications/pcn-1016-em1-led-die/)

Notes

- Cables and connectors are not included and must be ordered separately.
- US Digital® warrants its products against defects in materials and workmanship for two years. See complete warranty (<https://www.usdigital.com/company/warranty>) for details.