

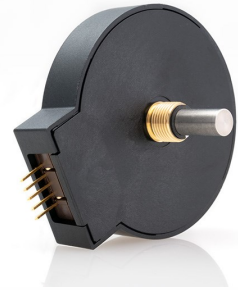

## S2 Features

- 2-channel quadrature, TTL square wave outputs
- 3rd channel index option
- 64 to 10,000 CPR (256 to 40,000 PPR)
- Ball-bearing option tracks to 10,000 RPM
- Wide operating temperature
- Single +5V supply



## S2 Product Description

The S2 series high-resolution optical shaft encoder is a non-contacting rotary to digital converter. Useful for position feedback or manual interface, the encoder converts real-time shaft angle, speed, and direction into TTL-compatible quadrature outputs with or without index. It operates from a single +5VDC supply.



The S2 is our first generation ball-bearing optical shaft encoder and is available for those customers who have designed it into their products; however, the S6 (<https://www.usdigital.com/products/encoders/incremental/shaft/s6/>) is recommended for new designs in place of the S2.

The S2 is designed to drive cables up to 10 feet long. For longer cable lengths, adding a PC4 (<https://www.usdigital.com/products/accessories/interfaces/cable-drivers/pc4/>)/PC5 (<https://www.usdigital.com/products/accessories/interfaces/cable-drivers/pc5/>) differential line driver is recommended.

Three shaft torque versions are available. The *standard torque* version has a sleeve bushing designed to provide torque and feel ideal for front panel human interface applications.

The *no torque added* option has a sleeve bushing that does not intentionally add torque for low RPM applications where a small amount of torque is acceptable.

The *ball-bearing* version uses miniature precision ball bearings that are suitable for high-speed and ultra-low torque applications.

Connection to the S2 series encoder is made through a 5-pin standard connector. The mating connectors are available from US Digital with several cable options and lengths.

## Mechanical Drawings

### S2 Optical Shaft Encoder

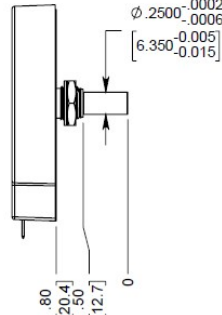
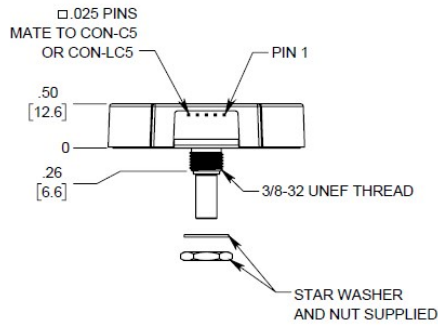
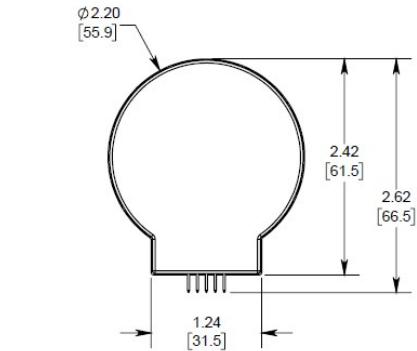

**BUSHING - .250" SHAFT**

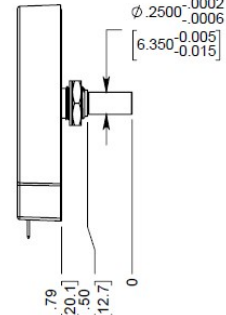

**BALL BEARING - .250" SHAFT**

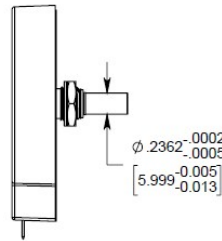

**BUSHING - .236" SHAFT**

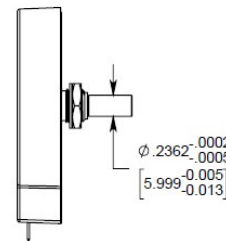

**BALL BEARING - .236" SHAFT**

RELEASE DATE: 12/18/2019

**US DIGITAL** 1400 NE 136th Avenue  
Vancouver, Washington 98684, USA

info@usdigital.com  
www.usdigital.com

Local: 360.260.2468  
Toll-free: 800.736.0194

UNITS: INCHES [MM]  
METRIC SHOWN FOR REFERENCE ONLY

## Specifications

### ENVIRONMENTAL

PARAMETER	VALUE	UNITS
Operating Temperature (CPR < 3600)	-40 to 100	C
Operating Temperature (CPR ≥ 3600)	-25 to 100	C
Vibration (5Hz to 2kHz)	20	G
Electrostatic Discharge, IEC 61000-4-2	± 4	kV



## MECHANICAL

PARAMETER	SLEEVE BUSHING	BALL BEARING
Max. Acceleration	250000 rad/sec <sup>2</sup>	250000 rad/sec <sup>2</sup>
Max. Shaft Speed (mechanical)	100 rpm (1)	10000 rpm (1)
Max. Shaft Torque	0.5 ±0.2 in-oz 0.3 in-oz (N-option)	0.05 in-oz
Max. Shaft Loading	2 lbs. dynamic 20 lbs. static	1 lb.
Bearing Life	> 1000000 revolutions	$L_{10} = (19.3/F_r)^3$ * Where $L_{10}$ = bearing life in millions of revs, and $F_r$ = radial shaft loading in pounds
Weight	1.28 oz.	1.28 oz.
Max. Shaft Runout	0.0015 in. T.I.R.	0.0015 in. T.I.R.
Max. Panel Nut Tightening Torque	20 in-lbs	20 in-lbs
Technical Bulletin TB1001 - Shaft and Bore Tolerances	Download ( <a href="https://www.usdigital.com/support/resources/reference/technical-docs/technical-bulletins/shaft-and-bore-tolerances-tb1001/">https://www.usdigital.com/support/resources/reference/technical-docs/technical-bulletins/shaft-and-bore-tolerances-tb1001/</a> )	

\* Only valid with negligible axial shaft loading.

(1) The maximum speed due to electrical considerations is dependent on the CPR. See the EM1 (<https://www.usdigital.com/products/encoders/incremental/modules/em1/>) and EM2 (<https://www.usdigital.com/products/encoders/incremental/modules/em2/>) product pages.

## PHASE RELATIONSHIP

B leads A for clockwise shaft rotation, and A leads B for counterclockwise rotation when viewed from the shaft side of the encoder.



## ELECTRICAL

- Specifications apply over the entire operating temperature range.
- Typical values are specified at  $V_{CC} = 5.0V_{DC}$  and  $25^{\circ}C$ .
- For complete details, see the EM1 (<https://www.usdigital.com/products/encoders/incremental/modules/em1/>) and EM2 (<https://www.usdigital.com/products/encoders/incremental/modules/em2/>) product pages.

PARAMETER	MIN.	TYP.	MAX.	UNITS	CONDITIONS
Supply Voltage	4.5	5.0	5.5	V	
Supply Current		27	33	mA	CPR < 1000, no load
		54	62	mA	CPR ≥ 1000 and < 3600, no load
		72	85	mA	CPR ≥ 3600, no load
Low-level Output			0.5	V	$I_{OL} = 8mA$ max., CPR < 3600
			0.5	mA	$I_{OL} = 5mA$ max., CPR ≥ 3600
		0.05		mA	no load, CPR < 3600
		0.25		mA	no load, CPR ≥ 3600
High-level Output	2.0			V	$I_{OH} = -8mA$ max., CPR < 3600
	2.0			V	$I_{OH} = -5mA$ max., CPR ≥ 3600
		4.8		V	no load, CPR < 3600
		3.5		V	no load, CPR ≥ 3600
Output Current Per Channel	-8		8	mA	CPR < 3600
	-5		5	mA	CPR ≥ 3600
Output Rise Time		110		nS	CPR < 3600
		50		nS	CPR ≥ 3600
Output Fall Time		35		nS	CPR < 3600
		50		nS	CPR ≥ 3600



## PIN-OUT

PIN	DESCRIPTION
1	Ground
2	Index
3	A channel
4	+5VDC power
5	B channel

**Note:** 5-pin single-ended mating connector is CON-C5 (<https://www.usdigital.com/products/accessories/connectors/con-c5/>) or CON-LC5 (<https://www.usdigital.com/products/accessories/connectors/con-lc5/>)



## PRODUCT CHANGE NOTIFICATIONS

Title	Date	Description	Download
S2 Housing Update - PCN 6935	1/13/2020	US Digital is implementing a redesign of the plastic housing components. The design changes are primarily an alteration of surface drafts and orientation of the housing components relative to each other. The new housing is dimensionally equivalent without any impact to form, fit or function within the envelope of the previous design.	Download <a href="https://www.usdigital.com/support/resources/product-change-notifications/pcn-6935-s2-housing-update/">(https://www.usdigital.com/support/resources/product-change-notifications/pcn-6935-s2-housing-update/)</a>
Laser Marking - PCN 5253	6/17/2015	As part of our ongoing continuous improvement efforts, US Digital is changing the labeling/marketing method for our E3, E6, H3, H6, S1, S2 and S6 products.	Download <a href="https://www.usdigital.com/support/resources/product-change-notifications/pcn-5253-laser-marking/">(https://www.usdigital.com/support/resources/product-change-notifications/pcn-5253-laser-marking/)</a>
EM1 & EM2 Update - PCN 4199	1/14/2014	Based on our continuous process improvement program, US Digital is changing the current marking method for our EM1 and EM2 encoder modules to a serialization method. This change will allow for each module to have a unique code; the current marking method is based on a date code system that includes all encoder modules produced within a specific week / year. The serialization system will be based on a hexadecimal system.	Download <a href="https://www.usdigital.com/support/resources/product-change-notifications/pcn-4199-em1-em2-update/">(https://www.usdigital.com/support/resources/product-change-notifications/pcn-4199-em1-em2-update/)</a>
EOL Sealed Housing Option - PCN 1021	4/11/2013	This PCN is a formal notification that US Digital is discontinuing the Sealed Housing option for the following products: <ul style="list-style-type: none"> <li>• A2 Absolute Optical Encoder</li> <li>• A2T Absolute Optical Inclinometer</li> <li>• H1 Ball Bearing Optical Shaft Encoder</li> <li>• H3 Ball Bearing Optical Shaft Encoder</li> <li>• S1 Optical Shaft Encoder</li> <li>• S2 Optical Kit Encoder</li> </ul> <p>The Sealed Housing option provides the encoder with low level capability of surviving in moisture environments, however the encoder is NOT waterproof or intended to be used in applications where this is required.</p>	Download <a href="https://www.usdigital.com/support/resources/product-change-notifications/pcn-1021-eol-sealed-housing-option/">(https://www.usdigital.com/support/resources/product-change-notifications/pcn-1021-eol-sealed-housing-option/)</a>
EM1 LED Die - PCN 1016	2/7/2013	As part of US Digital's continual assurance of supply strategy, we have qualified additional sources for our LED die used in our EM1 encoder module, which in turn impacts all of the following products: <p>EM1, E2, E3, E5, E6, H1, H15, H3, H5, H6, HB5M, HB6M, HD25, PE, S1, S2, S5, S6, T5 and T6</p> <p>The device specification will remain the same, i.e. there will be no change to form, fit or function of the product(s) as specified by US Digital. The appropriate quality and reliability testing has been performed on representative products to ensure normal parametric distribution, consistent with US Digital's quality and reliability standards.</p>	Download <a href="https://www.usdigital.com/support/resources/product-change-notifications/pcn-1016-em1-led-die/">(https://www.usdigital.com/support/resources/product-change-notifications/pcn-1016-em1-led-die/)</a>

## Notes

- Cables and connectors are not included and must be ordered separately.



## S2 OPTICAL SHAFT ENCODER

- For ordering information please see the Compatible Cables / Connectors section above.
- US Digital® warrants its products against defects in materials and workmanship for two years. See complete warranty (<https://www.usdigital.com/company/warranty>) for details.