

## Description

The E4 miniature encoder is designed to provide digital quadrature encoder feedback for applications with limited space constraints. The E4 utilizes a traditional set-screw codewheel which accommodates shaft sizes from 1.5mm to 4mm in diameter.

For high quantity OEM applications US Digital offers a cost saving OEM packaging option. When a set-screw is not required, the E4P is the ideal choice for high quantity OEM applications (see the E4P page).

The E4 base provides mounting holes for two #3-48, length 1/4" or two M2.5x.45mm, length 6mm screws on a .586" bolt circle. When mounting holes are not available, a pre-applied transfer adhesive (with peel-off backing) is available for "stick-on" mounting.

The internal components consist of a precision machined aluminum hub and an encoder circuit board module.

The encoder cover is easily snapped onto the base and is embossed with the connector pin-out.

The E4 series encoder can be connected by using a (high retention 4-conductor snap-in polarized 1.25mm pitch) connector. Mating cables and connectors (see the Cables / Connectors page) are not included and are available separately.



## Features

- ▶ Minimum shaft length of .285"
- ▶ Fits shaft diameters of .059" to .157" (1.5mm to 4mm)
- ▶ High retention snap-in polarized connector
- ▶ Accepts .020" (.5mm) axial shaft play
- ▶ Off-axis mounting tolerance of .010"
- ▶ Tracks from 0 to 60,000 cycles/sec
- ▶ 100 to 360 cycles per revolution (CPR)
- ▶ 400 to 1440 pulses per revolution (PPR)
- ▶ 2 channel quadrature TTL squarewave outputs
- ▶ -20 to +100 C operating temperature

## Mechanical Drawing

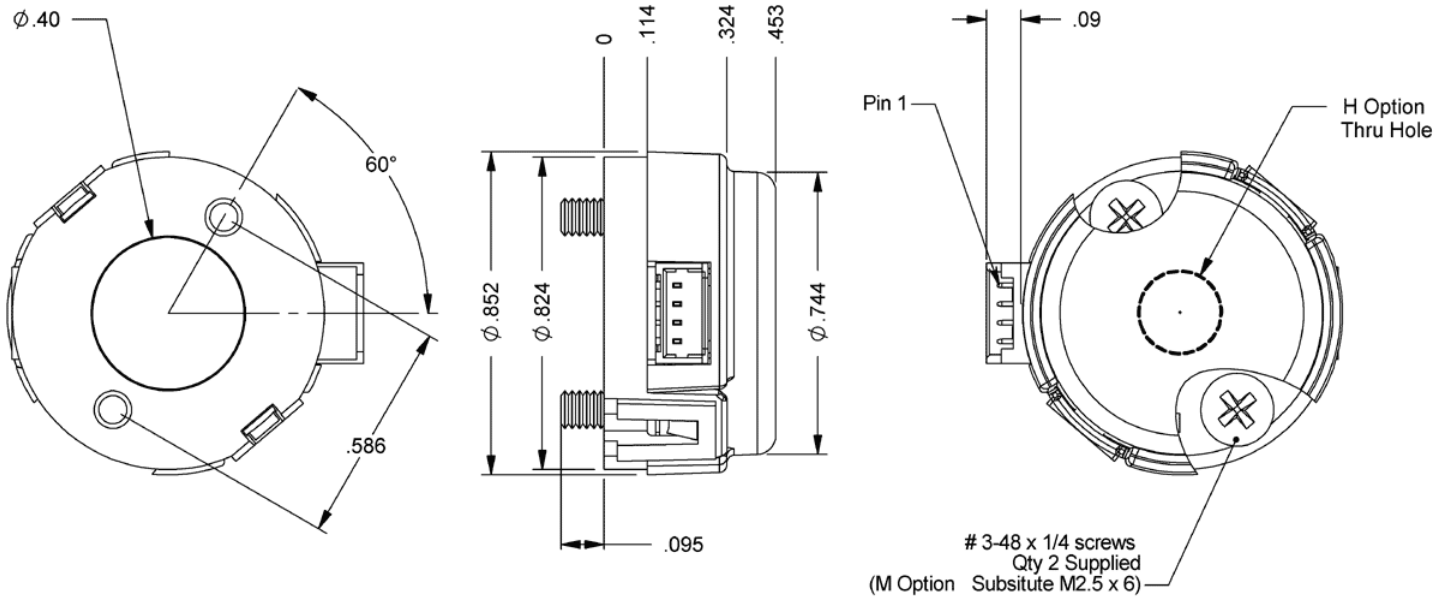

## Environmental

Parameter	Min.	Max.	Units
Vibration (5Hz to 2kHz)	-	20	G
Relative Humidity	-	90	%
Storage Temperature	-40	100	C
Operating Temperature	-20	100	C
ESD (Human Body Model JESD22-A114-A Class 2)	-	3	kV
ESD (Machine Model JESD22-A115-A Class B)	-	300	V

## Mechanical

Parameter	Value	Units
Moment of Inertia	7.4 x 10 <sup>-6</sup>	oz-in-s <sup>2</sup>
Hub Set Screw Size	#3-48 or #4-48	in.
Hex Wrench Size	.050	in.
Hub Setscrew Torque	1.5-2.0	in.-lbs.
Mounting Screw Size	#3-48 x 1/4"	-
M-option Screw Size	M2.5x.45mm, length 6mm	-
Screw Bolt Circle Diameter	.586 ± .002	in.

Parameter	Value	Units
Base Mounting Screw Torque	2-3	in.-lbs.
Required Shaft Length (1)	.285 to .395	in.
Shaft Axial Play	± .020	in.
Off-axis Mounting Tolerance	± .010	in.
Shaft to Mounting Surface Perpendicularity	90 ± 1	deg.
Acceleration	250000 max.	rad/sec <sup>2</sup>
Maximum RPM (2) e.x. CPR = 360, max. rpm = 10000 e.x. CPR = 100, max. rpm = 36000	minimum value of (3600000/CPR) and (60000)	rpm

(1) Includes axial play.

(2) 60000 rpm is the maximum rpm due to mechanical considerations. The maximum rpm due to the module's 60kHz maximum count frequency is (3600000/CPR).

## Electrical

Parameter	Min.	Typ.	Max.	Units	Notes
Power Supply Voltage	4.5	5.0	5.5	V	
Power Supply Current	-	21	27	mA	no load on outputs
High Level Output Voltage	2.4	-	-	V	IOH = -1.2 mA
Low Level Output Voltage	-	-	0.4	V	IOL = 6.0 mA
Rise Time	-	500	-	ns	CL = 25pF, RL = 2.7kOhm
Fall Time	-	100	-	ns	

## Phase Relationship



Parameter	Typ.	Units
Symmetry, S	180 ± 16	electrical degrees
Quadrature Delay, Q	90 ± 12	electrical degrees

A leads B for clockwise shaft rotation, B leads A for counter clockwise shaft rotation viewed from the shaft/bushing side of the encoder.

## Pin-out

Pin	Description
-----	-------------

1	+5VDC power
2	A channel
3	Ground
4	B channel

## Options

### H-option (Hole in Cover)

The **H**-option adds a hole in the cover for the shaft to pass through:

- For shaft diameters of 1.5mm to 1/8", a 0.170" hole is supplied.
- For shaft diameters of 5/32" and 4mm, a 0.295" hole is supplied.

### L-option (Low Power Strobe)

**L**-option To reduce the average power requirements, the **L**-option version of the **E4P** power can be strobed on just long enough to sample outputs A and B. This option is the same as our standard **E4P**, except the internal power bypass capacitor is not installed. The outputs settling time is typically 200 to 400 nano seconds after power up. The minimum sample frequency must be less than the maximum RPM X the CPR / 10.

### M-option (Metric Mounting Screws)

Provides alternate metric M2.5x.45mm, length 6mm screws. When **M**-option is NOT specified the default is #3-48 x 1/4" screws.

### T-option (Transfer Adhesive)

When mounting holes are not available, a pre-applied transfer adhesive (with peel-off backing) is available for "stick-on" mounting. Use the centering tool (above) to position the base. **T**-option specifies transfer adhesive.

## Accessories

### Centering Tools

Part #: MCTOOL - (Shaft Diameter\*)

**Description:** This reusable tool provides a simple method for accurately centering the **E4** base onto the shaft.

**Material:** Aluminum.

**Please note:** A centering tool is highly recommended when using the **T**-option transfer adhesive.

\* See Ordering Information below for available Shaft Diameters.

### Spacer Tool

Part #: SPACER-4216

**Description:** This reusable tool is used to properly space the codewheel from the encoder base. Nylon. Round. Provides air gap of 0.07" to 0.03".

### Hex Tools

Part #: HEXD-050

Description: Hex driver, .050" flat-to-flat for 3-48 or 4-48 set screws.

Part #: HEXW-050

Description: Hex wrench, .050" flat-to-flat for 3-48 or 4-48 set screws.

## Assembly Instructions

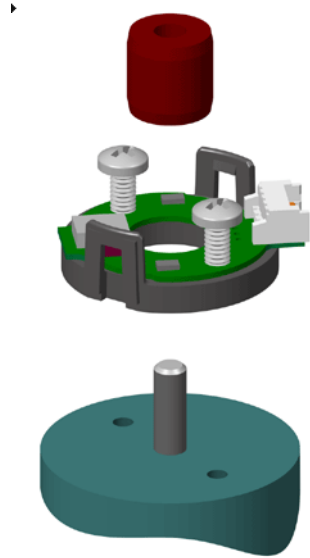

### 1. Base Mounting

Place base onto shaft. Secure base to mounting surface using two screws.

**Transfer Adhesive:** Peel off paper backing, place centering tool into center hole of base, slip centering tool onto shaft and slide base and centering tool down onto mounting surface as one piece. Press to form a good bond, then slip centering tool off shaft and continue with standard mounting instructions.

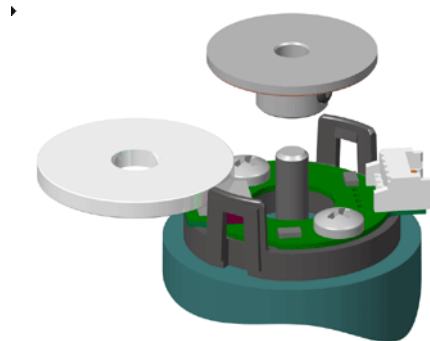

### 2. Spacer Installation

Place spacer tool on optic module as shown below.

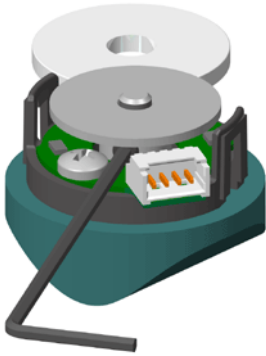

**3. Codewheel Installation**

Slip codewheel onto shaft until it bottoms out against spacer tool. Spacer tool provides an air gap of 0.07" 0.03". Tighten set screw with either the hex wrench / hex driver while pressing down on codewheel.

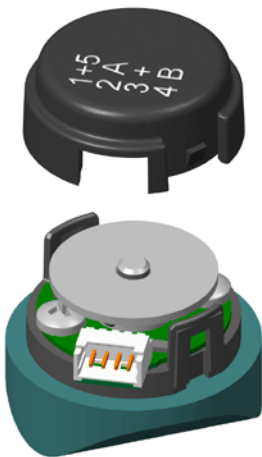

**4. Cover Installation**

Place housing (cover) on. With thumb and finger, squeeze ears together to insure that cover fully latches.

**Product Change Notifications**

Title	Date	Description	Download
E4 - E4P - S4 Update - PCN 1014	11/29/2011	We have modified the E4, E4P and S4 product lines in order to improve the performance and durability of the encoder. Changes include new molds for the plastic base and cover parts with an over-molded bushing in the S4 base, a new SMT connector (compatible with current mating connector), and a modified PCB profile to accommodate the new connector and plastic part modifications.	<a href="#">Download</a>

### Ordering Information

E4	CPR	Bore	Power	Cover	Base	Packaging
	100	059 =	D =	D =	D =Default	B =Encoder base, cover, hub/disk assembly, PCB, and screws are all packaged separately in bulk. The PCBs are in scored panels that are easily removed by the customer.
	108	1.5mm	Default	Default	M =Alternate metric	1 =Each encoder packaged individually. One spacer tool and one hex driver per 100 encoders.
	120	079 =	L =Low	H =Hole	M2.5x.45mm,length 6mm	2 =Each encoder packaged individually with one spacer tool and one hex wrench per encoder.
	125	2mm	Power	in Cover	screws	3 =Each encoder packaged individually with one spacer tool, one hex wrench, and one centering tool per encoder.
	128	091 =	Strobe		T =Transfer Adhesive	4 =Encoder base, PCB, and screws are pre-assembled. Base/PCB assembly, cover, and hub/disk assembly are all packaged separately in bulk. The Base/PCB assemblies are in scored panels that are easily removed by the customer.
	200	2.3mm				
	250	098 =				
	256	2.5mm				
	300	118 =				
	360	3mm				
		125 =				
		1/8"				
		156 =				
		5/32"				
		157 =				
		4mm				

### Notes

- Cables and connectors are not included and must be ordered separately.
- For ordering information please see the Compatible Cables / Connectors section above.
- US Digital warrants its products against defects in materials and workmanship for two years. See complete warranty for details.

### Base Pricing

Quantity	Price
1	\$51.50
5	\$33.50

For volume discounts, please contact us at sales@usdigital.com or 800.736.0194.

- Add 15% per unit for **Base** of Transfer Adhesive
- Add \$3.00 per unit for **Packaging** of Each encoder packaged individually. One spacer tool and one hex driver per 100 encoders.
- Add \$4.00 per unit for **Packaging** of Each encoder packaged individually with one spacer tool and one hex wrench per encoder.
- Add \$7.00 per unit for **Packaging** of Each encoder packaged individually with one spacer tool, one hex wrench, and one centering tool per encoder.

- Add \$0.50 per unit for **Packaging** of Encoder base, PCB, and screws are pre-assembled. Base/PCB assembly, cover, and hub/disk assembly are all packaged separately in bulk. The Base/PCB assemblies are in scored panels that are easily removed by the customer.