

Description

The AEDR encoder module, manufactured by Avago Technologies, uses reflective technology to sense rotary or linear position. This sensor consists of an LED light source and a photodetector IC in a single surface mount package. When used with a reflective codewheel or codestrip, this device can sense rotary or linear position.

The reflective surface mount optical encoders provide two square wave outputs in quadrature for count and direction information. These TTL compatible outputs correspond to the alternating reflective/non-reflective pattern of the codewheel or codestrip.

The AEDR reflective optical encoder modules are available in four resolutions of 75, 150, 180, and 212 LPI (lines per inch).

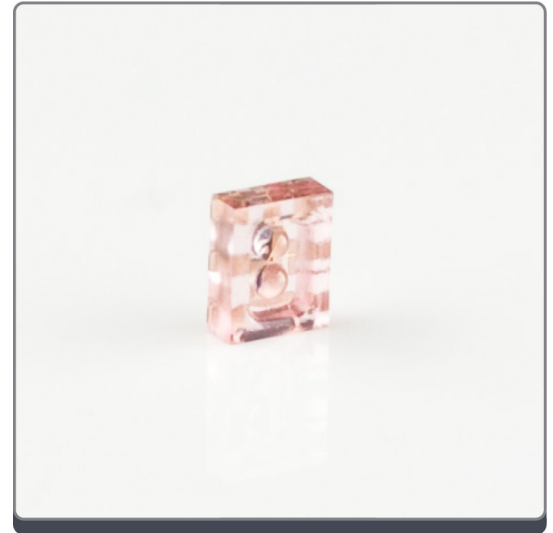

Features

- ▶ Reflective technology
- ▶ Surface mount SO-6 package
- ▶ Two channel quadrature outputs for direction sensing
- ▶ Available in four encoding resolutions
- ▶ Small size
- ▶ TTL compatible
- ▶ Single +5V supply

Mechanical Drawing

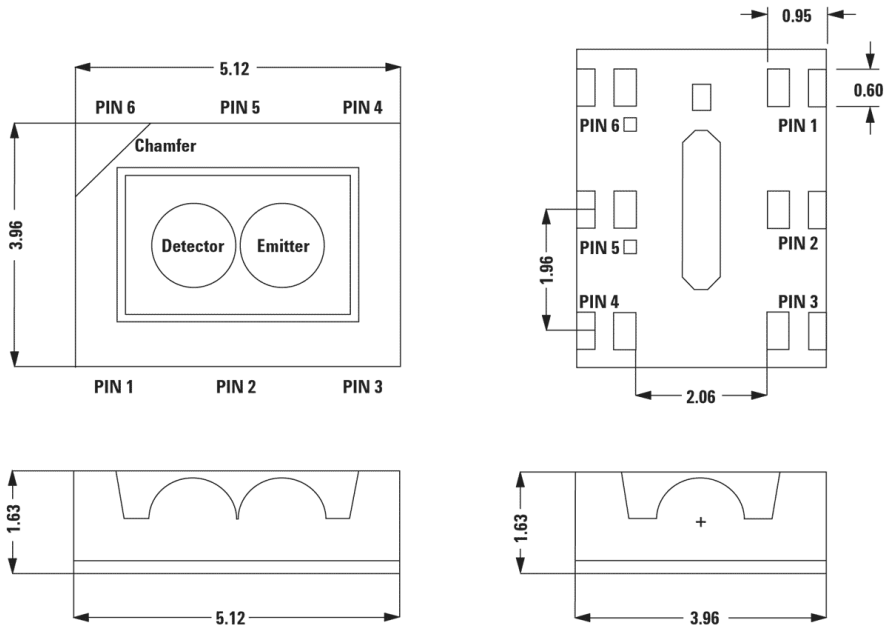

All dimensions in millimeters.
Tolerance x.xx ± 0.15 mm.

Pin-out / Block Diagram

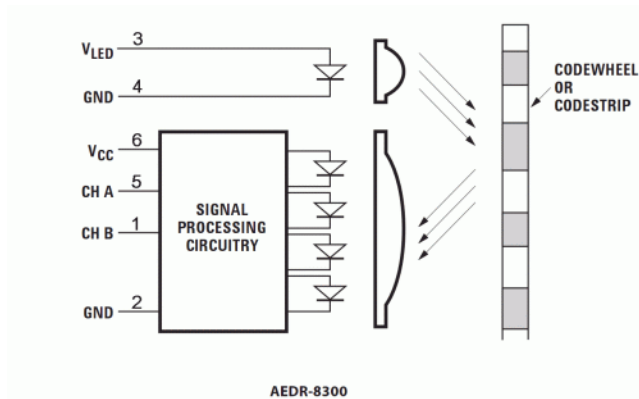

Recommended Operating Conditions

Parameter	Min.	Typ.	Max.	Units	Notes
Operating Temperature	-20	25	85	C	
Storage Temperature	-40		85	C	
Supply Voltage	4.5	5.0	5.5	Volts	Ripple (<100mV P-P)
LED Current	13	15	18	mA	With external 220 ohm series resistor(see below)
Load Capacitance	-	-	100	pF	2.7K-ohms Pull-up

Parameter	Min.	Typ.	Max.	Units	Notes
Count Frequency	-	-	60	kHz	(rpm/60) x cycles/rev.
Angular Misalignment	-1.5	0	+1.5	deg.	
Codewheel / Codestrip Tilt	-	0	1	deg.	
Codewheel / Codestrip Gap	1.00	2.00	2.50	mm	
	0.04	0.08	0.10	in.	
Radial Misalignment	-0.38	-	+0.38	mm	
	-0.015	-	+0.015	in.	
Tangential Misalignment	-0.38	-	+0.38	mm	
	-0.015	-	+0.015	in.	

- Specifications apply over entire operating temperature range.
- Values are for the worst error over a full rotation.
- An external series resistor to limit the LED current is required. The recommended value is 220 ohm in series between the Vcc (pin 6) and VLED (pin 3).

Encoding Characteristics

Parameter	Typ.	Max.	Units
Symmetry Error (Ch. A, Ch. B) - 8300-K	15, 25	55, 75	° e
Symmetry Error (Ch. A, Ch. B) - 8300-P, 8300-Q, 8300-W	16	75	° e
Quadrature Error - 8300-K	12	60	° e
Quadrature Error - 8300-P, 8300-Q, 8300-W	10	60	° e

Electrical

Parameter	Min.	Typ.	Max.	Units	Notes
Detector Supply Current	-	2.2	5.0	mA	
High Level Output Voltage	2.4	-	-	V	IOH = -0.2 mA
Low Level Output Voltage	-	-	0.4	V	IOL = 8.00 mA
Rise Time	-	500	-	ns	CL = 25pF, RL = 2.7kOhm
Fall Time	-	100	-	ns	
ESD	-	-	-	-	Human Body Model JESD22-A114-A Class 2 Machine Model JESD22-A115-A Class B

- Specifications apply over entire operating temperature range.

› Values are for the worst error over full rotation.

Phase Relationship

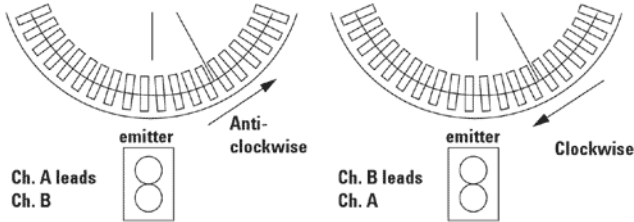

Timing Diagram

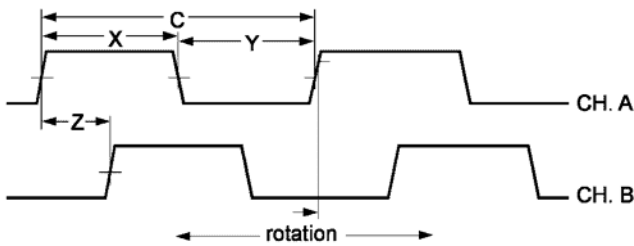

CPR (N):

The number of Cycles Per Revolution.

One Shaft Rotation:

360 mechanical degrees, N cycles.

One Electrical Degree (e):

1/360th of one cycle.

One Cycle (C):

360 electrical degrees (e). Each cycle can be decoded into 1, 2, or 4 codes, referred to as X1, X2, or X4 resolution multiplication.

Symmetry:

A measure of the relationship between (X) and (Y) in electrical degrees, nominally 180e.

Quadrature (Z):

The phase lag or lead between channels A and B in electrical degrees, nominally 90e.

Position Error:

The difference between the actual shaft position and the position indicated by the encoder cycle count.

Cycle Error:

An indication of cycle uniformity. The difference between an observed shaft angle which gives rise to one electrical cycle, and the nominal angular increment of 1/N of a revolution.

Mounting

The AEDR should be mounted parallel to the window/bar orientation, as shown below. The emitter side (pins 3 and 4) should be placed closer to the rotating shaft.

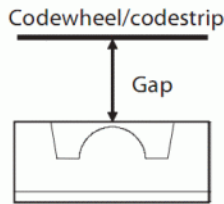
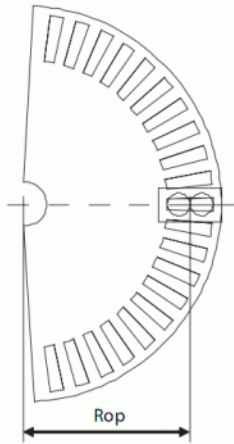
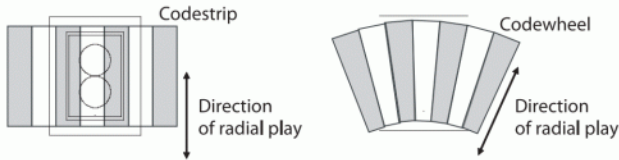

11.00 mm (0.433 IN) < Rop < ∞

Ordering Information

AEDR -

Configuration

8300-K = 75 LPI, clear package

8300-P = 150 LPI, red package

8300-Q = 180 LPI, amber package

8300-W = 212 LPI, light amber package

Notes

- US Digital warrants its products against defects in materials and workmanship for two years. See complete warranty for details.

Base Pricing

Quantity	Price
1	\$7.25
10	\$6.35

For volume discounts, please contact us at sales@usdigital.com or 800.736.0194.